

Water

Electro-chemical treatment of Cooling tower water and blowdown minimization

water savers

To use water efficiently in the cooling tower system, the cycles of concentration must be maximized. This is accomplished by minimizing the amount of the required blowdown that normally happens due to increase of salts concentrations. Treating the water reduces the make-up water demand. The degree to which the cycles can be maximized depends on the water chemistry within the cooling tower and the water chemistry of the make-up water supply. The treatment of the cooling tower water also helps the system in corrosion protection and microbiological growth and contamination.

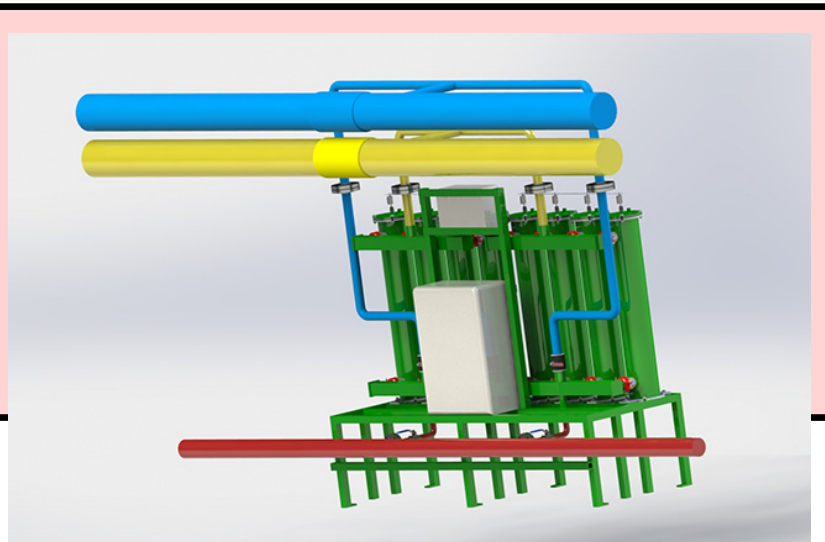
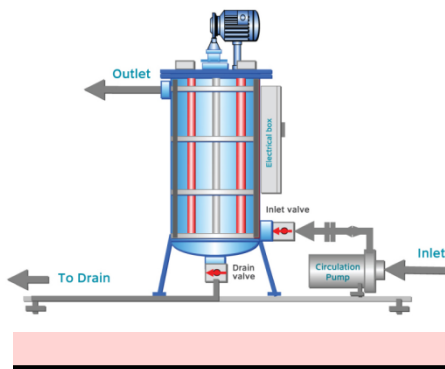

Potential use in hotel industry

- Cooling tower blowdown minimization

Advantages

Disadvantages

Solves cooling tower problems stemming from algae, corrosion and scaling

Additional professional water treatment requirements

Reduces maintenance



Water

Electro-chemical treatment of Cooling tower water and blowdown minimization water savers

Part 2 –Performance, Case studies

Table 6-1. Percent of Make-Up Water Saved by Maximizing Cycles of Concentration

		New Concentration Ratio (CRf)										
		2	2.5	3	3.5	4	5	6	7	8	9	10
Initial Concentration Ratio (Cri)	1.5	33%	44%	50%	53%	56%	58%	60%	61%	62%	63%	64%
	2.0	-	17%	25%	30%	33%	38%	40%	42%	43%	44%	45%
	2.5	-	-	10%	16%	20%	25%	28%	30%	31%	33%	34%
	3.0	-	-	-	7%	11%	17%	20%	22%	24%	25%	26%
	3.5	-	-	-	-	5%	11%	14%	17%	18%	20%	21%
	4.0	-	-	-	-	-	6%	10%	13%	14%	16%	17%
	5.0	-	-	-	-	-	-	4%	7%	9%	10%	11%
	6.0	-	-	-	-	-	-	-	3%	5%	6%	7%

CASE A : UET improved the efficiency of the air-conditioning system for the surgery building of a major Israeli hospital complex, which was using soft water and salt to tackle scale build-up in the water cooling system. This product is designed for pre-treatment of feed water to reverse-osmosis systems

And eliminated the problems of scale build-up, increased their water conductivity, and reduced their use of water softeners and salt.

Total Water Savings were about 45% and chemical were not added any more.

CASE B : Electrochemical Treatment Unit Installed in Central Ohio Chemical Processing Plant. The Elgressy Electrochemical Scale Treatment System (EST) was installed on one (1100 T.R) of the two cooling towers on site. Although a direct year to year comparison is difficult because of load changes, it is clear that the EST system is saving water with the increase in cycles of concentration. It was estimated that the water savings was in excess of 2.2 million gallons if all operating conditions were the same

Part 3 –Companies manufacturing/implementing the technology

- Elgressy, <https://www.elgressy.com/solutions/cooling-towers-treatment-est/>
- UET, <https://www.uet.co.il/product/cooling-tower-system/>

